

Pro Range Emergency Twin Spot

brightLED
...BRIGHTENING YOUR FUTURE

Non-maintained with 5-year battery warranty

5-Year
Warranty
(inc. battery)



5-Year
Self-Test
Option



Overview

BrightLED Smart Emergency Twin Spots are ICEL endorsed and manufactured to provide full compliance to current standards, including BS 60598-2-22 and ISO 7010. Each spot can be individually rotated and angled to ensure the correct coverage.

Features

- IP65 self-contained emergency twinspace
- IK10 impact rating
- Low stand-by power consumption < 0.5W
- Self-test version available
- Li-ion battery with a 5-year warranty
- 5-year warranty on cell & electronics
- Non-maintained 350lm in emergency mode
- Suitable for indoor or outdoor applications
- Remote control optional

Product Dimensions

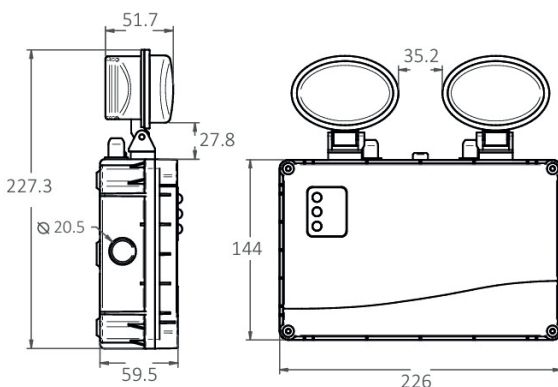

E: office@bright-led.co.uk
T: 01282 505400 F: 0844 854 8662

www.bright-led.co.uk



Front view



Side view



Back view

Photometric Performance

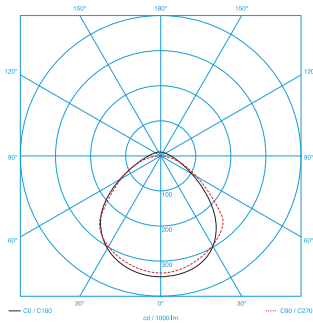

Product Specification

Code	Description
EPS-FXTS-350-L	Emergency Twin Spot NM 350lm Manual Test Lithium - 5-year battery warranty
EPS-FXTS-350-ESL	Emergency Twin Spot NM 350lm Self-Test Lithium - 5-year battery warranty

